



KEYSTONE

The Keystone Series GR is a heavy duty industrial resilient seated butterfly valve aimed at general purpose applications.

Features

- Wafer and lugged body design with face-to-face dimension, according to EN 558 Series 20 and API 609.
- Designed according to EN 593 and API 609.
- The seat is field replaceable and fully isolates the body and shaft from the flow.
- Primary shaft sealing exceeds the pressure rating of the valve and prevents leakage through shaft area to atmosphere.
- A secondary shaft sealing provides back-up safety.
- A molded-in O-ring in the seat for flange sealing eliminates the need for gaskets.
- Shaft seals prevent moisture penetrating into the shaft area.
- The two piece shaft allows for a thin disc and provides minimal obstruction to flow (up to NPS 12).
- Rounded polished disc edge gives full concentric sealing, lower torques, longer seat life and drop-tight shut-off.
- Body locating holes allow ease of installation and centering between the flanges.
- Extended body neck allows for pipe insulation.
- Top and bottom shaft bearings for optimized support and minimum friction and decreased torque.
- Top bushing absorbs actuator side thrust loads.
- All valves comply to Pressure Equipment Directive (97/23/EU) Module B1 + D, CE Marking.
- Available approvals: KIWA, ABS, WRAS, ACS, NSF/ANSI STD 61.



General application

Water, air, dry bulk conveying etc. These valves are for any service where a drop-tight shut-off with maximum flow area is required.

Technical data

Pressure (psi)	: 230 psi NPS 2-12 150 psi NPS 14-36
End of line (psi)	: 150 psi NPS 2-12 90 psi NPS 14-36
Vacuum service (psia)	: 5.8 psia
Temperature (°F)	: -40 to +320
Sizes (NPS)	: 2-36

Flange accommodation : PN 6/10/16
ASME 125/150
JIS 10K
BS Table E
AS4087 PN 16
AS2129 Table E

Keystone Series GR Resilient Seated Butterfly Valves

GRW/GRL Sizes NPS 2-36

Series GRW/GRL NPS 2-12 (GRW shown)

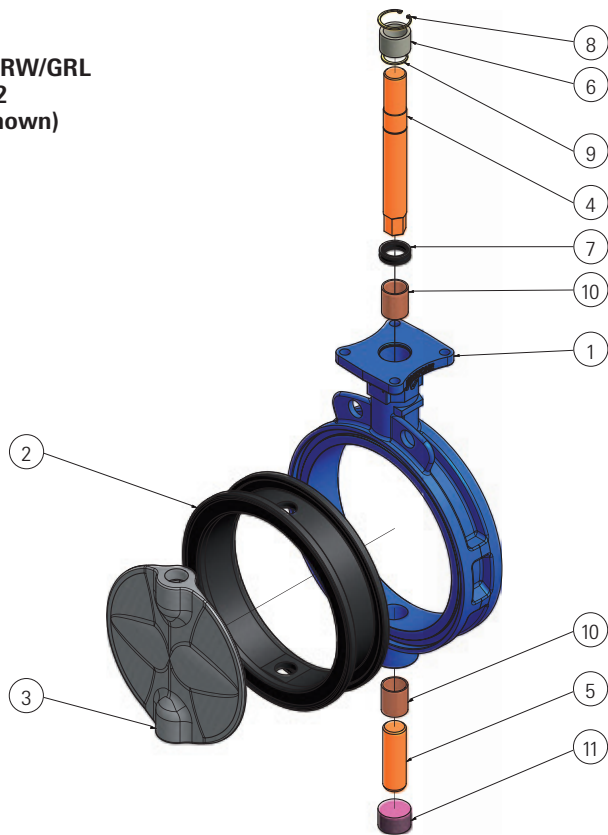

Parts list

Item	Qty	Description
1	1	Body
2	1	Seat
3	1	Disc
4	1	Upper shaft
5	1	Lower shaft
6	1	Upper bushing
7	1	Packing
8	1	Body circlip
9	1	Shaft circlip
10	2	Upper and lower bearing
11	1	Plug

NPS 14-36 (GRL shown)

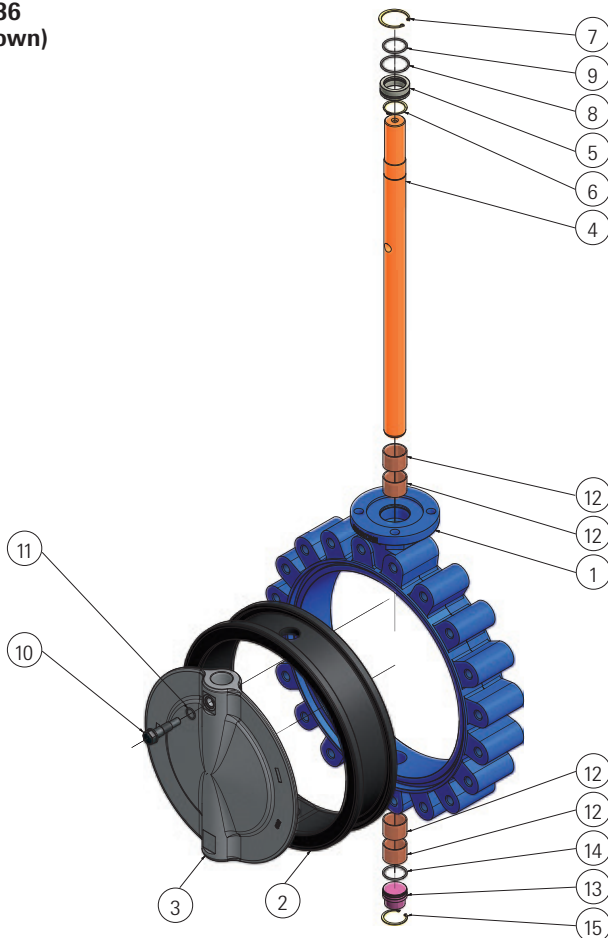

Parts list

Item	Qty	Description
1	1	Body
2	1	Seat
3	1	Disc
4	1	Shaft
5	1	Bushing
6	1	Shaft circlip
7	1	Body circlip
8	1	Body O-ring
9	1	Shaft O-ring
10	1	Disc screw
11	1	Disc screw O-ring
12	4	Upper and lower bearing
13	1	Plug
14	1	Plug O-ring
15	1	Plug circlip

Material specification

NPS 2-12

Part name	Material	Material specification	Remark
Body	Ductile iron	ASTM A536 Gr 65-45-12 ASTM A395 Gr 60-40-18	(Optional)
Disc	Super duplex 316 stainless steel 304 stainless steel Aluminium bronze Nickel aluminium bronze Ductile iron CTD	ASTM A890 Gr 5A ASTM A351 Gr CF8M ASTM A351 Gr CF8 ASTM B148 UNS C95200 ASTM B148 UNS C95800 ASTM A536 Gr 65-45-12	CTD = Nickel plating
Shaft	316 stainless steel 431 stainless steel Super duplex	ASTM A276 Gr 316 ASTM A276 Gr 431 ASTM A276 UNS S32750	
Seat	EPDM NBR White NBR Fluoroelastomer (FKM)		Food grade Food grade Food grade
Bushing	Polyester		
Packing	NBR		
Bearing	PTFE/steel		
Circlip	Stainless steel		
Plug	Carbon steel		

NPS 14-36

Body	Ductile iron	ASTM A536 Gr 65-45-12 ASTM A395 Gr 60-40-18	(Optional)
Disc	Super duplex Duplex 316 stainless steel 304 stainless steel Aluminium bronze Nickel aluminium bronze Ductile iron CTD	ASTM A890 Gr 5A ASTM A890 Gr 4A ASTM A351 Gr CF8M ASTM A351 Gr CF8 ASTM B148 UNS C95200 ASTM B148 UNS C95800 ASTM A536 Gr 65-45-12	CTD = Epoxy coated, max. temp. 250°F
Shaft	431 stainless steel Duplex Super duplex	ASTM A276 Gr 431 S43100 ASTM A276 UNS S31803 ASTM A276 UNS S32750	
Seat	EPDM NBR FKM		Food grade Food grade
Disc screw	Super duplex Duplex	ASTM A276 UNS S32750 ASTM A276 UNS S31803	
Disc screw O-ring	EPDM NBR FKM		
Plug	Carbon steel		
Plug O-ring	NBR		
Plug circlip	Stainless steel		
Bushing	Polyester		
Shaft/Body O-ring	NBR		
Bearing	PTFE/steel		
Shaft/Body circlip	Stainless steel		

Note:

Valves with super duplex disc will have super duplex disc screw. All other discs will have a duplex disc screw.

Keystone Series GR Resilient Seated Butterfly Valves

GRW/GRL Sizes NPS 2-36

Series GRW (Wafer)

NPS 2-12

NPS 14-36

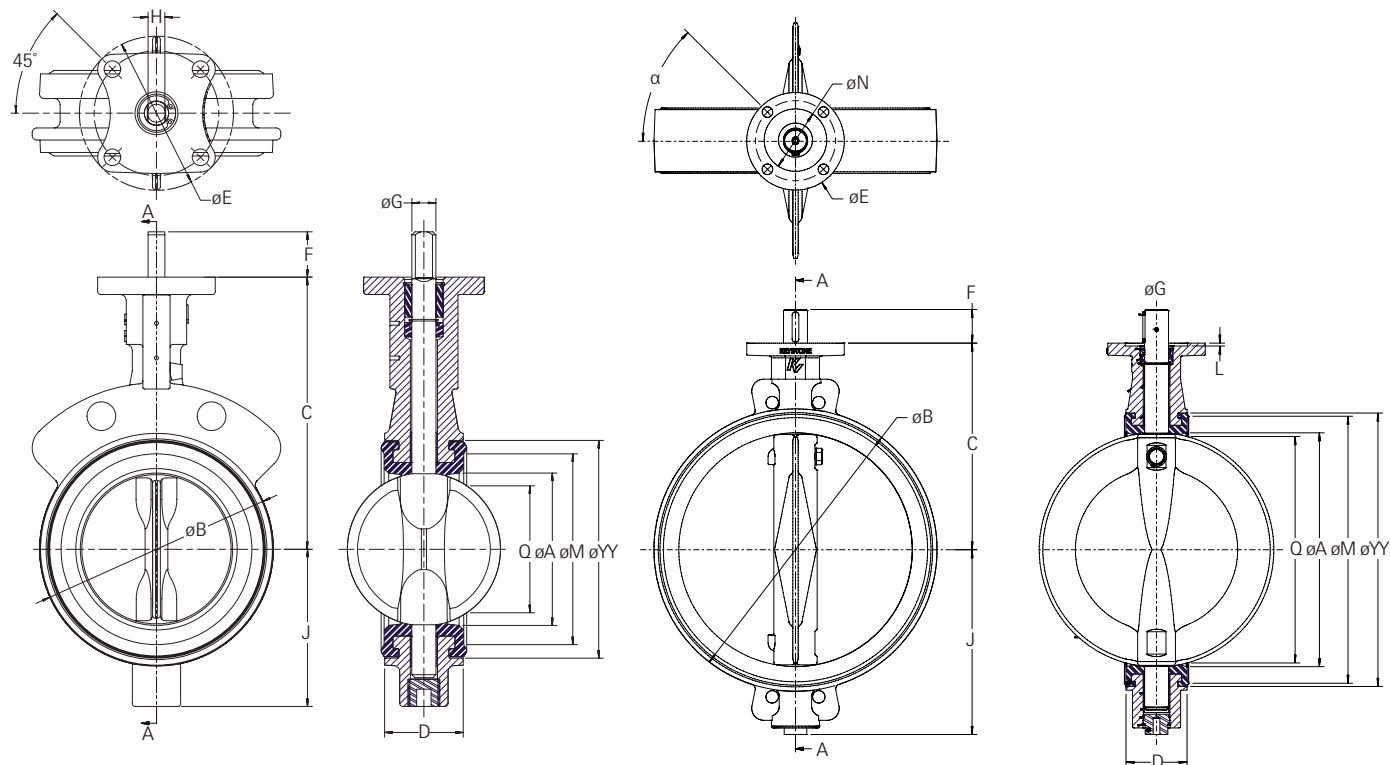

Valve dimensions (in)

Size (NPS)	A	B	C	D	E	F	J	L	M	N	Q (1)	YY	Shaft			Top plate drilling			Adapt. code (4)	Weight (3) (lbs)	
													G	H (2)	Key	Bolt circle	No. holes	Hole dia.			
2	1.97	3.58	5.31	1.69	3.94	0.98	2.36	-	2.60	-	1.10	3.15	5/8	7/16	-	3/4	4	45°	0.43	BAC	4.5
2.5	2.44	4.13	5.91	1.81	3.94	1.18	2.99	-	3.07	-	1.70	3.66	9/16	3/8	-	3/4	4	45°	0.43	BAB	6
3	3.03	4.84	6.30	1.81	3.94	1.18	3.23	-	3.82	-	2.56	4.41	9/16	3/8	-	3/4	4	45°	0.43	BAB	7
4	3.90	6.06	7.09	2.05	3.94	1.18	4.09	-	5.08	-	3.43	5.67	5/8	7/16	-	3/4	4	45°	0.43	BAC	9.5
5	4.88	7.36	7.68	2.20	3.94	1.18	4.72	-	6.30	-	4.45	6.89	3/4	1/2	-	3/4	4	45°	0.43	BAD	13
6	5.91	8.19	8.27	2.20	3.94	1.18	5.16	-	7.13	-	5.59	7.72	3/4	1/2	-	3/4	4	45°	0.43	BAD	15
8	7.68	10.43	9.45	2.36	5.91	1.26	6.38	-	9.17	-	7.40	9.76	7/8	5/8	-	5	4	45°	0.53	CAE	26
10	9.65	12.6	10.83	2.68	5.91	1.97	7.80	-	11.42	-	9.33	12.011	1/8	-	1/4 x 1/4	5	4	45°	0.53	CAF	42
12	11.46	14.65	12.20	3.07	5.91	1.97	9.06	-	13.39	-	11.14	13.981	1/8	-	1/4 x 1/4	5	4	45°	0.53	CAF	59
14	12.80	16.38	12.80	3.07	5.90	2.99	10.24	-	14.88	-	12.50	15.671	3/8	-	5/16 x 5/16	5	4	45°	0.53	CAG	88
16	14.96	18.66	14.17	4.02	5.90	2.99	11.73	-	17.13	-	14.50	17.911	3/8	-	5/16 x 5/16	5	4	45°	0.53	CAG	134
18	17.09	21.02	15.55	4.49	8.00	2.99	13.15	0.24	19.49	5.12	16.60	20.281	5/8	-	3/8 x 3/8	6 1/2	4	45°	0.87	DAH	190
20	19.13	23.19	16.93	5.00	8.00	4.25	15.16	0.24	21.61	5.12	18.60	22.401	7/8	-	1/2 x 3/8	6 1/2	4	45°	0.87	DAJ	234
24	23.03	27.20	19.69	6.06	8.00	4.25	17.95	0.24	25.59	5.12	22.30	26.381	7/8	-	1/2 x 3/8	6 1/2	4	45°	0.87	DAJ	348
28	26.97	31.50	22.44	6.50	8.00	4.25	20.39	0.24	29.72	5.12	26.30	30.512	1/4	-	1/2 x 3/8	6 1/2	4	45°	0.87	DAK	509
30	28.94	33.94	23.82	6.50	8.00	4.25	21.69	0.24	32.13	5.12	28.30	32.872	1/4	-	1/2 x 3/8	6 1/2	4	45°	0.87	DAK	597
32	30.91	35.71	25.20	7.48	11.81	5.51	22.95	0.24	33.86	7.87	30.10	34.652	7/8	-	3/4 x 1/2	10	8	22.5°	0.69	KAV	719
36	34.84	39.65	28.15	7.99	11.81	5.51	25.94	0.24	37.80	7.87	34.00	38.582	7/8	-	3/4 x 1/2	10	8	22.5°	0.69	KAV	924

Notes:

- (1) 'Q' dimension is the minimum allowable pipe or flange inside diameter at the centered body face to protect the disc sealing edge against damage when opening the valve.
- (2) 'H' dimension refers to flat on shaft.
- (3) Weight may vary depending on trim materials used.
- (4) NPS 2 - actual shaft dimension is 1/2 in x 1/3 in A/F and is fitted with an adaptor to produce a BAC connection.

Series GRL (Lug) NPS 2-12

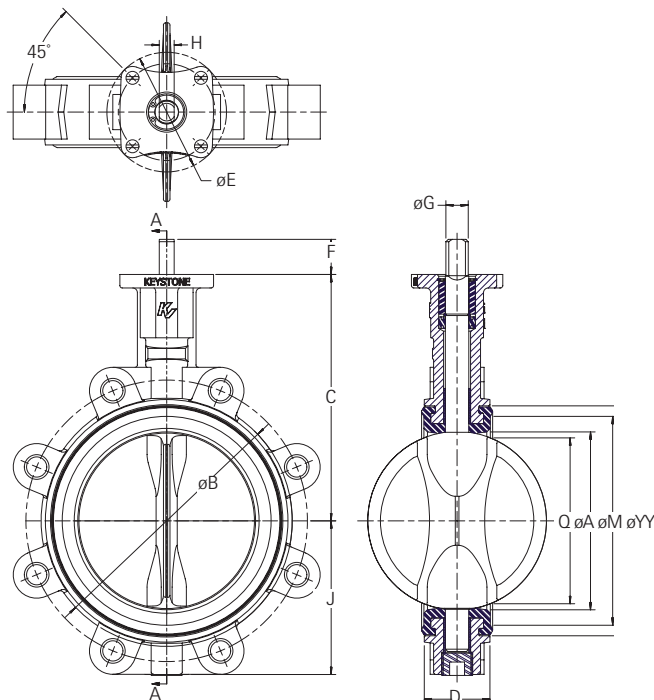

NPS 14-36

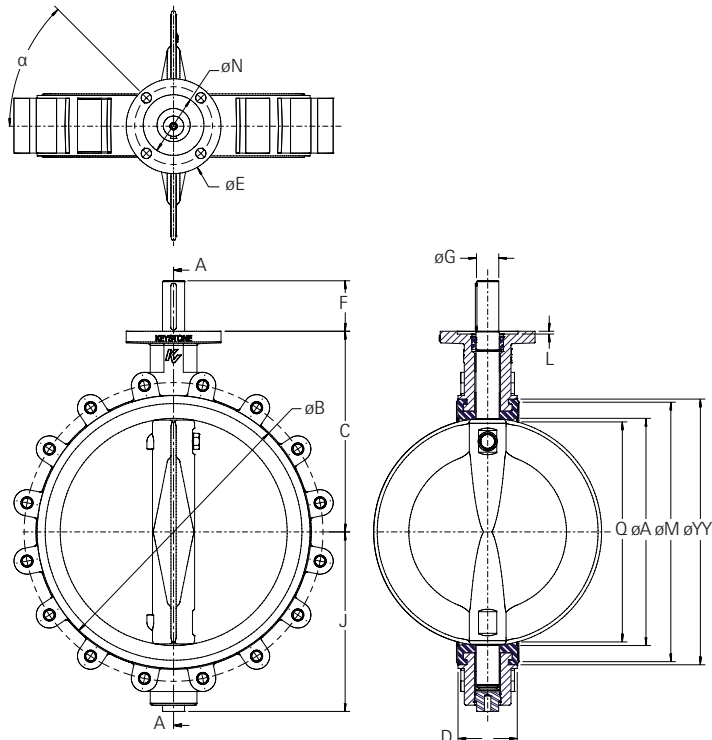

Valve dimensions (in)

Size (NPS)	A	B	C	D	E	F	J	L	M	N	Q ⁽¹⁾	YY	Top plate drilling								
													Shaft			Bolt circle	No. holes	Hole α	Hole dia.	Adapt. code ⁽⁴⁾	Weight ⁽³⁾ (lbs)
													G	H ⁽²⁾	Key						
2	1.97	3.62	5.31	1.69	3.94	0.98	2.36	-	2.60	-	1.10	3.15	5/8	7/16	-	3 1/4	4	45°	0.43	BAC	7
2.5	2.44	4.13	5.91	1.81	3.94	1.18	2.99	-	3.07	-	1.70	3.66	9/16	3/8	-	3 1/4	4	45°	0.43	BAB	9
3	3.03	4.96	6.30	1.81	3.94	1.18	3.23	-	3.82	-	2.56	4.41	9/16	3/8	-	3 1/4	4	45°	0.43	BAB	10
4	3.90	6.14	7.09	2.05	3.94	1.18	4.09	-	5.08	-	3.43	5.67	5/8	7/16	-	3 1/4	4	45°	0.43	BAC	15
5	4.88	7.48	7.68	2.20	3.94	1.18	4.72	-	6.30	-	4.45	6.89	3/4	1/2	-	3 1/4	4	45°	0.43	BAD	21.5
6	5.91	8.43	8.27	2.20	3.94	1.18	5.16	-	7.13	-	5.59	7.72	3/4	1/2	-	3 1/4	4	45°	0.43	BAD	24
8	7.68	10.55	9.45	2.36	5.91	1.26	6.38	-	9.17	-	7.40	9.76	7/8	5/8	-	5	4	45°	0.53	CAE	38
10	9.65	12.60	10.83	2.68	5.91	1.97	7.80	-	11.42	-	9.33	12.01	1 1/8	-	1/4 x 1/4	5	4	45°	0.53	CAF	65
12	11.46	14.76	12.20	3.07	5.91	1.97	9.06	-	13.39	-	11.14	13.98	1 1/8	-	1/4 x 1/4	5	4	45°	0.53	CAF	90
14	12.80	16.38	12.80	3.07	5.90	2.99	10.24	-	14.88	-	12.51	15.67	1 3/8	-	5/16 x 5/16	5	4	45°	0.53	CAG	115
16	14.96	18.66	14.17	4.02	5.90	2.99	11.73	-	17.13	-	14.50	17.91	1 3/8	-	5/16 x 5/16	5	4	45°	0.53	CAG	194
18	17.09	21.02	15.55	4.49	8.00	2.99	13.15	0.24	19.49	5.12	16.58	20.28	1 5/8	-	3/8 x 3/8	6 1/2	4	45°	0.87	DAH	236
20	19.13	23.19	16.93	5.00	8.00	4.25	15.16	0.24	21.61	5.12	18.56	22.40	1 7/8	-	1/2 x 3/8	6 1/2	4	45°	0.87	DAJ	355
24	23.03	27.20	19.69	6.06	8.00	4.25	17.95	0.24	25.59	5.12	22.35	26.38	1 7/8	-	1/2 x 3/8	6 1/2	4	45°	0.87	DAJ	518
28	26.97	31.50	22.44	6.50	8.00	4.25	20.39	0.24	29.72	5.12	26.30	30.51	2 1/4	-	1/2 x 3/8	6 1/2	4	45°	0.87	DAK	694
30	28.94	33.94	23.82	6.50	8.00	4.25	21.69	0.24	32.13	5.12	28.31	32.87	2 1/4	-	1/2 x 3/8	6 1/2	4	45°	0.87	DAK	833
32	30.91	35.71	25.20	7.48	11.81	5.51	22.95	0.24	33.86	7.87	30.12	34.65	2 7/8	-	3/4 x 1/2	10	8	22.5°	0.69	KAV	966
36 ⁽⁵⁾	34.84	39.65	28.15	7.99	11.81	5.51	25.94	0.24	37.80	7.87	34.03	38.58	2 7/8	-	3/4 x 1/2	10	8	22.5°	0.69	KAV	1232

Notes:

- (1) 'Q' dimension is the minimum allowable pipe or flange inside diameter at the centered body face to protect the disc sealing edge against damage when opening the valve.
- (2) 'H' dimension refers to flat on shaft.

- (3) Weight may vary depending on trim materials used.
- (4) NPS 2 - actual shaft dimension is 1/2 in x 1/2 in in A/F and is fitted with an adaptor to produce a BAC connection.
- (5) Valve size NPS 36 is tapped flange design and has no separate lugs.

Series GRW & GRL

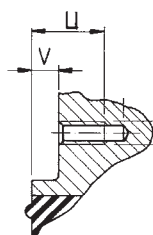

Dimensions of tapped flange locating holes (in)

Size (NPS)	Series GRW		Series GRL	
	U	V	U	V
28	1.8	0.22	1.8	0.22
30	2.1	0.49	1.8	0.22
32	2.4	0.79	1.8	0.22
36	2.1	0.26	2.1	0.26

Note:

All holes in lugged version are through threaded, except the holes closest to top and bottom shaft.

Keystone Series GR Resilient Seated Butterfly Valves

GRW/GRL Sizes NPS 2-36

Torque application factor categories

Application I

Clean liquid lubricating media (water, clean oils, lube oil, mineral oil, etc.); and with no deposit or chemical attack, valve operated at least once a week.

Temperature range from 32°F to maximum temperature rating of the elastomer seat.

Application II

Other liquid media and lubricating gases (aqueous liquids, such as food & beverage, water, etc.); and with minor deposit or chemical attack, valve operated at least once a month.

Temperature range from 32°F to maximum temperature rating of the elastomer seat.

Application III

a. Dry non-abrasive media or gases (non-abrasive powders and dry gas); or

b. Fluids with moderate deposit or chemical attack; or

c. Valves operated less than once a month.

Temperature range from 32°F to maximum temperature rating of the elastomer seat.

Application IV

a. Dry abrasive media and degreasing applications (sand, cement, silicone free, oxygen cleaned); or

b. Liquids with severe deposit; or

c. Valves not frequently operated (once a year).

All above with temperature range from 15°F to maximum temperature rating of the elastomer seat.

Notes:

- For applications with temperatures above or below the guidelines above, please consult factory.
- For dry service valves it is suggested to use U/C discs (reduced diameter) when service conditions are less than 50 psi.

Valve seating and unseating torques (in lbs)

Differential pressure (psi)	Valve size (NPS)																	
	2	2.5	3	4	5	6	8	10	12	14	16	18	20	24	28	30	32	36
Application I																		
50	115	168	230	327	513	717	1310	2133	3054	4137	5654	7479	9635	15043	22076	26264	30933	39137
100	115	177	239	354	558	779	1452	2399	3425	4605	6363	8500	11048	17518	26045	31164	36899	46688
150	124	186	266	389	620	876	1664	2788	3992	5262	7360	9936	13038	21007	31641	38076	45315	57340
200	133	204	292	434	708	1000	1938	3310	4744									
230	133	221	319	451	752	1062	2080	3567	5116									
50 (U/C)	69	101	138	196	308	430	786	1280	1832	2482	3393	4487	5781	9026	13246	15758	18560	23482
Application II																		
50	124	186	257	372	584	823	1496	2425	3469	4673	6354	8364	10728	16617	24218	28723	33731	42679
100	124	195	274	398	628	885	1637	2682	3841	5129	7048	9366	12118	19059	28142	33572	39638	50155
150	133	204	292	434	690	982	1841	3071	4408	5770	8023	10775	14074	22498	33670	40404	47966 ⁽¹⁾	60695
200	142	230	319	478	779	1106	2124	3593	5160									
230	150	239	336	496	823	1168	2257	3859	5541									
50 (U/C)	74	112	154	223	350	494	897	1455	2082	2804	3812	5018	6437	9970	14531	17234	20239	25607
Application III																		
50	133	204	283	425	655	929	1682	2708	3885	5208	7053	9249	11821	18191	26361	31183	36529	46220
100	142	212	301	443	699	991	1823	2974	4257	5654	7733	10233	13188	20600	30239	35979	42378	53622
150	142	230	319	478	761	1080	2027	3363	4824	6277	8685	11614	15109	23989	35700	42734	50617 ⁽¹⁾	64050
200	150	248	354	522	850	1204	2310	3885	5567									
230	159	257	363	540	894	1266	2443	4142	5948									
50 (U/C)	80	122	170	255	393	558	1009	1625	2331	3125	4232	5550	7093	10915	15817	18710	21918	27732
Application IV																		
50	152	233	330	491	764	1081	1956	3141	4503	6012	8103	10577	13461	20552	29575	34872	40727	51533
100	157	242	344	513	807	1143	2095	3401	4878	6440	8760	11533	14794	22912	33385	39591	46487	58823
150	163	257	366	547	873	1237	2304	3792	5441	7038	9680	12872	16663	26226	38744	46229	54593 ⁽¹⁾	69083
200	171	275	394	591	959	1362	2582	4313	6191									
230	175	285	408	613	1003	1425	2721	4574	6567									
50 (U/C)	91	140	198	295	458	648	1174	1884	2702	3607	4862	6346	8076	12331	17745	20923	24436	30920

Notes:

50 U/C refers to reduced diameter disc option.

⁽¹⁾ Duplex shaft not suitable for these conditions, use only 431 stainless steel or super duplex.

Keystone Series GR Resilient Seated Butterfly Valves

GRW/GRL Sizes NPS 2-36

Maximum allowable shaft torques (in lbs)

Shaft material	Valve size (NPS)																	
	2	2.5	3	4	5	6	8	10	12	14	16	18	20	24	28	30	32	36
316SS	575	975	975	1415	2300	2300	3360	6740	6740									
431SS	800	1370	1370	2035	3230	3230	5750	11570	11570	13650	16140	26350	29490	45010	55860	63100	62750	130500
Duplex										10230	12110	19760	21370	33770	41900	47300	47050	97900
Super duplex	750	1260	1260	1860	3010	3010	5310	10620	10620	12510	14800	24150	26115	38640	47950	54150	53850	112000

Flowrate co-efficients - C_v values

Valve size (NPS)	Disc opening (degrees)								
	10°	20°	30°	40°	50°	60°	70°	80°	90°
2	0	1.0	6	16	35	54	83	114	125
2.5	0	2.8	13	31	58	90	142	199	251
3	0	7	32	64	105	163	249	351	473
4	0	16	66	126	205	306	471	694	933
5	0	32	98	183	289	450	728	1114	1446
6	8	60	150	261	424	668	1141	1793	2250
8	25	133	267	468	747	1190	2050	3364	4065
10	39	200	392	741	1133	1787	3095	5143	6712
12	57	292	572	1081	1653	2607	4514	7757	10301
14	138	351	736	1320	2238	3595	5792	10369	12031
16	179	459	962	1725	2924	4696	7565	13542	15713
18	227	582	1217	2183	3699	5943	9582	17140	19888
20	280	718	1503	2695	4568	7338	11820	21160	24553
24	403	1034	2163	3881	6577	10566	17021	30471	35356
28	549	1406	2945	5282	8953	14382	23168	41474	48123
30	630	1614	3380	6064	10277	16510	26595	47610	55243
32	717	1837	3846	6899	11692	18784	30259	54170	62854
36	908	2325	4868	8732	14799	23773	38297	68558	79550

Note:

C_v = The volume of water in U.S.gpm that will pass through a valve with a pressure drop of 1 psi at 70°F.

Pressure-temperature diagram

Seat material *	Disc material	Body material	Size range (NPS)	Valve function Standard / End of Line	Temperature (°F)									
					-20	0	32	122	212	248	266	302	320	
EPDM	all	DI	2-12	Std / EOL				230 psi / 150 psi						
NBR and white NBR	all	DI	2-12	Std / EOL			230 psi / 150 psi							
FKM	all	DI	2-12	Std / EOL				230 psi / 150 psi				150 psi/90 psi		
EPDM	all	DI	14-36	Std / EOL				150 psi / 90 psi						
NBR	all	DI	14-36	Std / EOL				150 psi / 90 psi						
FKM	all	DI	14-36	Std / EOL					150 psi / 90 psi				90 psi/60 psi	

Notes:

* all seat materials drop tight

For non-PED requirements with EPDM seats, valves can be rated to a minimum temperature of -40°F.

Keystone Series GR Resilient Seated Butterfly Valves

GRW/GRL Sizes NPS 2-36

Ordering information

Example:

NPS 4 Series GR Lug style, Ductile iron body,
316SS disc, 431SS shaft, EPDM seat,
ASME 125/150, Keystone mount, bare shaft, U/C disc
GRL 4 D12E A1 K B0 UC

GR L 4 D 1 2 E A1 K B0 UC

Series

GR

Body style

L – Lug

W – Wafer

Size (NPS)

2	4	8	14	20	30
2.5	5	10	16	24	32
3	6	12	18	28	36

Body material

D – Ductile iron ASTM A536

N – Ductile iron ASTM A395

Disc material

1 – 316 stainless steel **4** – Ductile iron / ENP (NPS 2-12) **7** – Super duplex

2 – 304 stainless steel **5** – Ductile iron / Epoxy ctd. (NPS 14-36) **N** – Nickel aluminium bronze

3 – Aluminum bronze **6** – Duplex

Shaft (1,2)

1 – 316 stainless steel

6 – Duplex

2 – 431 stainless steel

7 – Super duplex

Notes:

(1) The standard material is 431 stainless steel.

316 stainless steel shaft is available as an option in NPS 2-12.

(2) NPS 14-36 valves with a super duplex disc will have a super duplex disc screw.

All other disc materials will have a duplex disc screw.

Seat

E – EPDM (Food grade)

F – Fluoroelastomer (FKM)

N – NBR (Food grade)

W – White NBR (Food grade)

Flange drilling

Single drilled

A1 – ASME 125/150

AE – AS2129 Table E

D1 – DIN PN 6

D3 – DIN PN 16

AD – AS4087 PN 16

B1 – BS Table E

D2 – DIN PN 10

J2 – JIS 10K

Multidrilled (Wafer only)

M3 – ASME 125/150, AS2129 Table E (NPS 2-24)

Mounting

K – Keystone actuator mount

Actuation

B0 – Bare shaft

G1 – Gear

P1 – Pneumatic DA

E – Electric

H1 – 10 pos handle

C1 – Chainwheel

P2 – Pneumatic SR

Special (If none leave blank)

UC – Under cut disc for 50 psi or less pressure

P – Special body coating

MTR – Material certifications

SF – Silicone free

DOC – Special documentation

Pentair Valves & Controls provides the information herein in good faith but makes no representation as to its comprehensiveness or accuracy. This data sheet is intended only as a guide to Pentair products and services. Individuals using this data sheet must exercise their independent judgment in evaluating product selection and determining product appropriateness for their particular purpose and system requirements. PENTAIR MAKES NO REPRESENTATIONS OR WARRANTIES, EITHER EXPRESS OR IMPLIED, INCLUDING WITHOUT LIMITATION ANY WARRANTIES OF MERCHANTABILITY OR FITNESS FOR A PARTICULAR PURPOSE WITH RESPECT TO THE INFORMATION SET FORTH HEREIN OR THE PRODUCT(S) TO WHICH THE INFORMATION REFERS. ACCORDINGLY, PV&C WILL NOT BE RESPONSIBLE FOR DAMAGES (OF ANY KIND OR NATURE, INCLUDING INCIDENTAL, DIRECT, INDIRECT, OR CONSEQUENTIAL DAMAGES) RESULTING FROM THE USE OF OR RELIANCE UPON THIS INFORMATION. Patents and Patents Pending in the U.S. and foreign countries. Pentair reserves the right to change product designs and specifications without notice. All registered trademarks are the property of their respective owners. Printed in the USA.